

## SENSOR WITH UV LED EMISSION AND PLASTIC HOUSING



- *High sensitivity and powerful UV LED emission*
- *Fast switching frequency and low response time*
- *Easy sensor setting by means of two Up/Down push-buttons*
- *Sturdy plastic housing with standard dimensions and fixing holes*

## LD50 SERIES

The **LD50** luminescence sensor line offers the best solution for all the applications where cost reduction is requested, without compromising the excellent detection performances. The optimised optics of these sensors, together with the powerful UV LED emission and the high receiving sensitivity of visible light, allow the detection of the weakest luminescence level, like in case of small fluorescent markings, with the highest immunity from the surface colour or reflectivity variations.

Thanks to only two 'Up' and 'Down' push-buttons for sensitivity increase and decrease, the sensor setting is very easy and intuitive. Furthermore, different luminescence levels present on the same surface can be distinguished.

**LD50** sensors can find typical applications on packaging machinery for food, cosmetic or pharmaceutical goods, for the detection of papermade luminescent targets, like labels on reflective surface or sheets placed inside transparent or semi-open boxes.

Other frequent applications can be found in ceramic, wood, textile or mechanical industries, always for fluorescent parts or marks detection.

Thanks to the compact dimensions and multiple fixing holes with metallic inserts present in standard positions, the sturdy ABS plastic housing is fully compatible and can replace the most traditional luminescent sensors, also offering an interesting cost reduction.

## SETTING

The sensitivity of the sensor can be adjusted, in order to detect objects with different luminescence levels.

The sensitivity level can be increased or decreased step by step by means of UP or DOWN push-buttons.

The orange LED blinks with a frequency which is proportional to the sensitivity level.

The maximum sensitivity can be set by pressing both the UP and DOWN push-buttons at the same time, in this case the orange LED turns on without blinking.

## DIMENSIONS

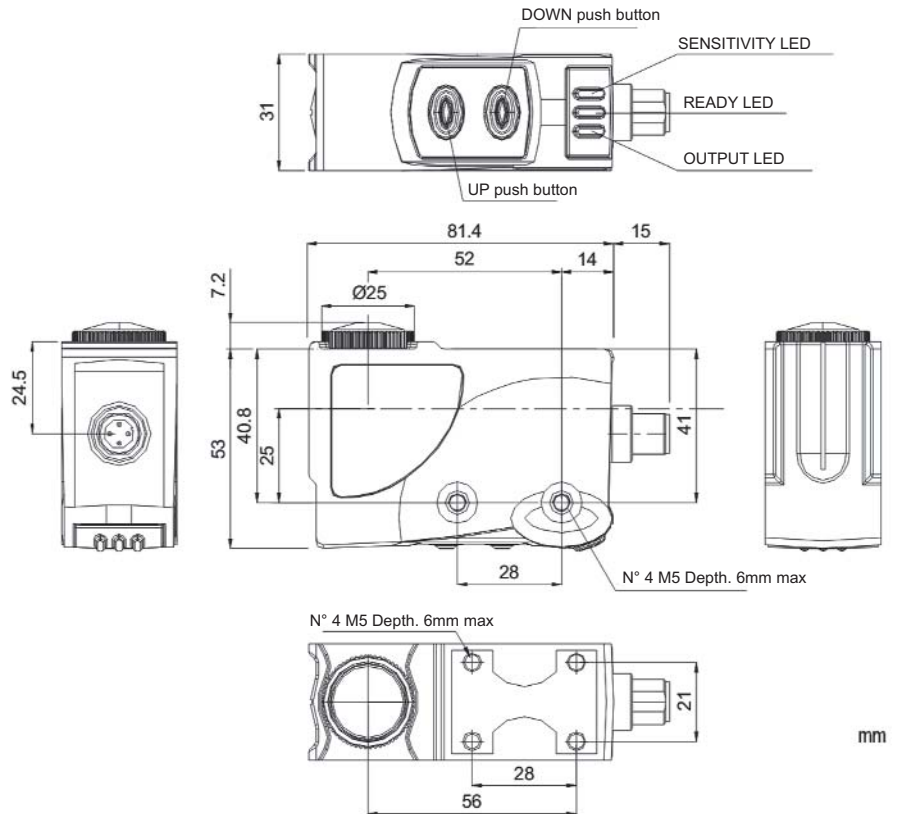

## INDICATORS AND PUSH-BUTTONS

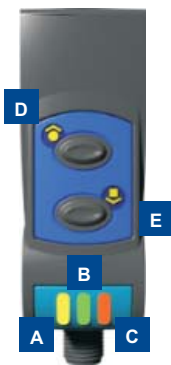

- |                                 |                           |
|---------------------------------|---------------------------|
| <b>A</b> yellow OUTPUT LED      | <b>D</b> UP push-button   |
| <b>B</b> green READY LED        | <b>E</b> DOWN push-button |
| <b>C</b> orange SENSITIVITY LED |                           |

## ACCESSORIES

For dedicated accessories refer to the ACCESSORIES section of this catalogue.

Refer also to Connectors of the General Catalogue.

## CONNECTIONS

### M12 CONNECTOR

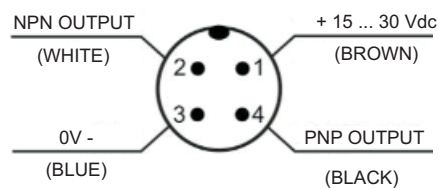

## TECHNICAL DATA

Power supply:	15 ... 30 Vdc, reverse polarity protection
Consumption:	50 mA max at 24 Vdc
Light emission:	LED UV, 375 nm <sup>1</sup>
Spot dimension:	2 x 6 mm at 10 mm
Operating distance:	10 ... 20 mm
Setting:	manual using UP and DOWN push-buttons
Indicators:	yellow OUTPUT LED green READY LED orange SENSITIVITY LED
Output type:	1 NPN 1 PNP
Output current:	100 mA max.
Saturation voltage:	≤ 2 V
Response time:	250 μs
Switching frequency:	2 kHz
Operating mode:	light
Connections:	M12 4-pole connector
Electrical protection:	Class 2
Mechanical protection:	IP67
Protection devices:	A, B <sup>2</sup>
Housing material:	ABS
Lens material:	glass
Weight:	180 g max.
Operating temperature:	-10...55°C
Storage temperature:	-20...70°C
Reference standard:	EN 60947-5-2

## TECHNICAL NOTES

<sup>1</sup> Average life of 100.000 h with  $T_A = +25\text{ °C}$

<sup>2</sup> A - reverse polarity protection  
B - overload and short-circuit protection



## DETECTION DIAGRAMS

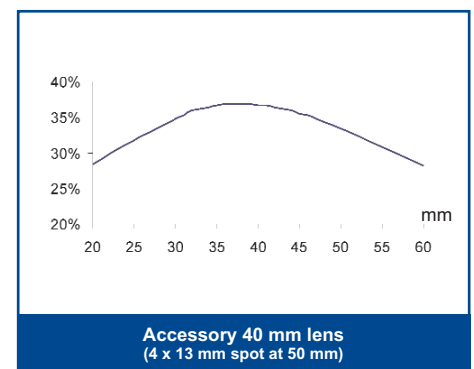
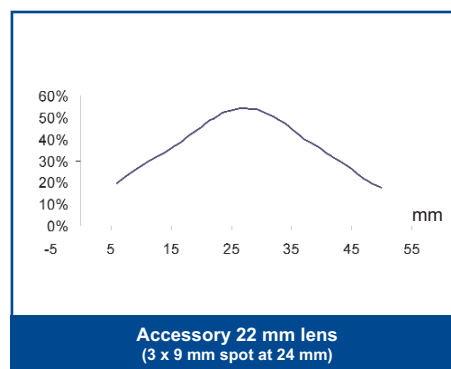
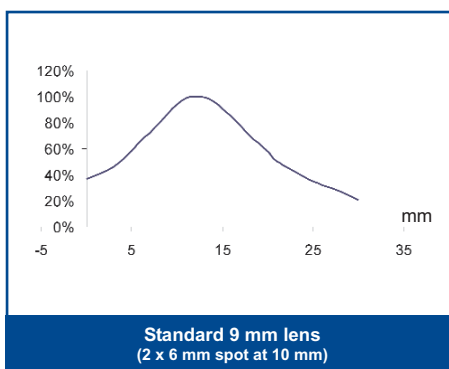

## MODEL SELECTION AND ORDER INFORMATION

MODEL	OPERATING DISTANCE	ORDER N°
LD50-U-715	10 - 20 mm	955251000

## ACCESSORY LENSES

## DIMENSIONS

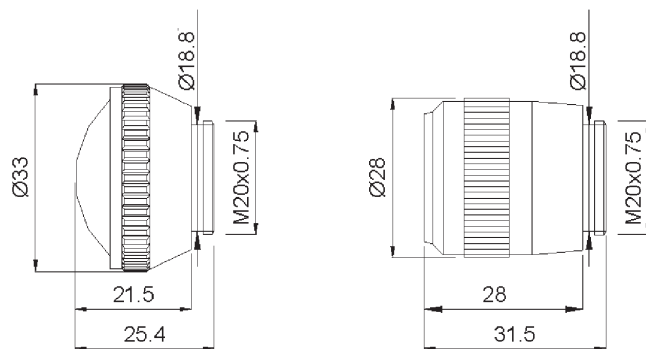

Lens 40 mm glass

Lens 22 mm glass

mm

## ACCESSORY SELECTION AND ORDER INFORMATION

MODEL	DESCRIPTION	ORDER N°
Lens No.22 glass	glass lens with 22 mm focus	95ACC1100
Lens No.40 glass	glass lens with 40 mm focus	95ACC2740

Please refer also to **Sensor Accessories**



Distributed by:

### HEADQUARTERS

**DATASENSOR SpA**  
 via Lavino, 265 - 40050 Monte San Pietro, BO - Italy  
 Tel. +39 051/6765611 • Fax +39 051/6759324  
[www.datasensor.com](http://www.datasensor.com) • e-mail [info@datasensor.com](mailto:info@datasensor.com)

DATASENSOR SpA endeavours to continuously improve and renew its products; for this reason the technical data and contents of this catalogue may undergo variations without prior notice. For correct installation and use DATASENSOR SpA can guarantee only the data indicated in the instruction manual supplied with the products.